

Candidate Name _____

Centre Number	Candidate Number

CAMBRIDGE INTERNATIONAL EXAMINATIONS
Joint Examination for the School Certificate
and General Certificate of Education Ordinary Level

PHYSICS
PAPER 2 Theory

5054/2

OCTOBER/NOVEMBER SESSION 2002

1 hour 45 minutes

Candidates answer on the question paper.
Additional materials:
Answer paper
Graph paper

TIME 1 hour 45 minutes

INSTRUCTIONS TO CANDIDATES

Write your name, Centre number and candidate number in the spaces at the top of this page and on any separate answer paper used.

Section A

Answer **all** questions.

Write your answers in the spaces provided on the question paper.

Section B

Answer any **two** questions.

Write your answers on the separate answer paper provided.

At the end of the examination, fasten any separate answer paper used securely to the question paper.

INFORMATION FOR CANDIDATES

The number of marks is given in brackets [] at the end of each question or part question.

Candidates are reminded that **all** quantitative answers should include appropriate units.

Candidates are advised to show all their working in a clear and orderly manner, as more marks are awarded for sound use of physics than for correct answers.

FOR EXAMINER'S USE	
Section A	
Q9	
Q10	
Q11	
TOTAL	

This question paper consists of 12 printed pages.



Section A

Answer **all** the questions in this section.

- 1 Fig. 1.1 shows a car travelling at a uniform speed of 18 m/s. At time $t = 0$, the driver sees a child run out in front of the car.



Fig. 1.1

At time $t = 0.6$ s the driver starts to apply the brakes. The car then decelerates uniformly, taking a further 3.0 s to stop.

- (a) (i) On Fig. 1.2, draw a graph to show how the speed of the car varies with t .

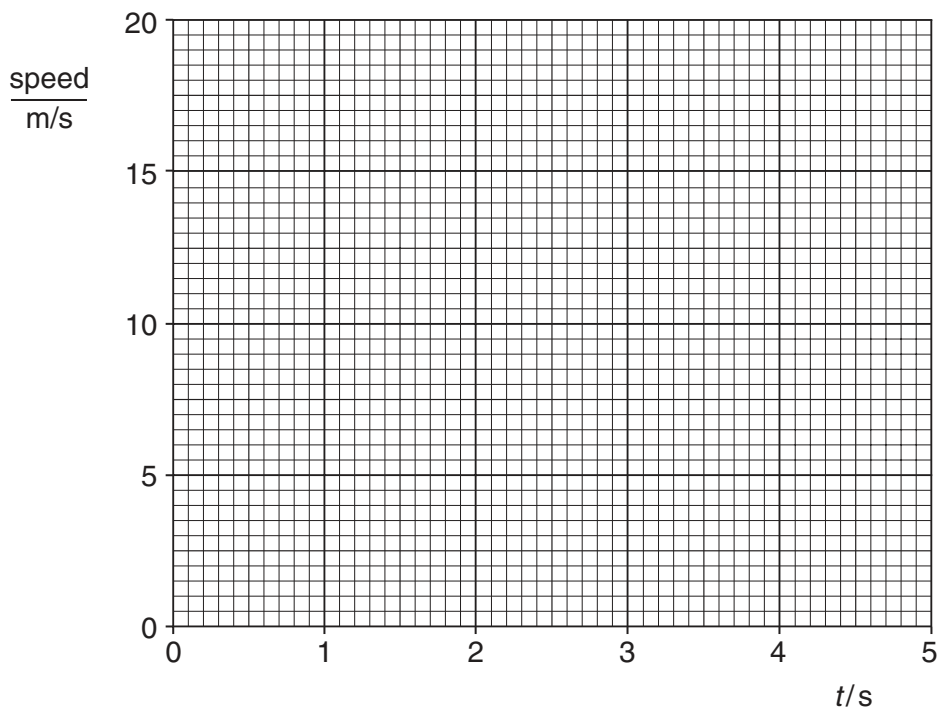

Fig. 1.2

- (ii) Calculate the distance travelled in the first 0.6 s of the motion.

distance = [5]

- (b) The braking distance is the distance travelled by the car after the driver starts to apply the brakes. The braking distance is not the same each time that the car stops.

State two factors that could increase braking distance.

1.

.....

2.

..... [2]

2 Fig. 2.1 shows a ray of light **PQR** passing along a simple optical fibre to its end at **R**.

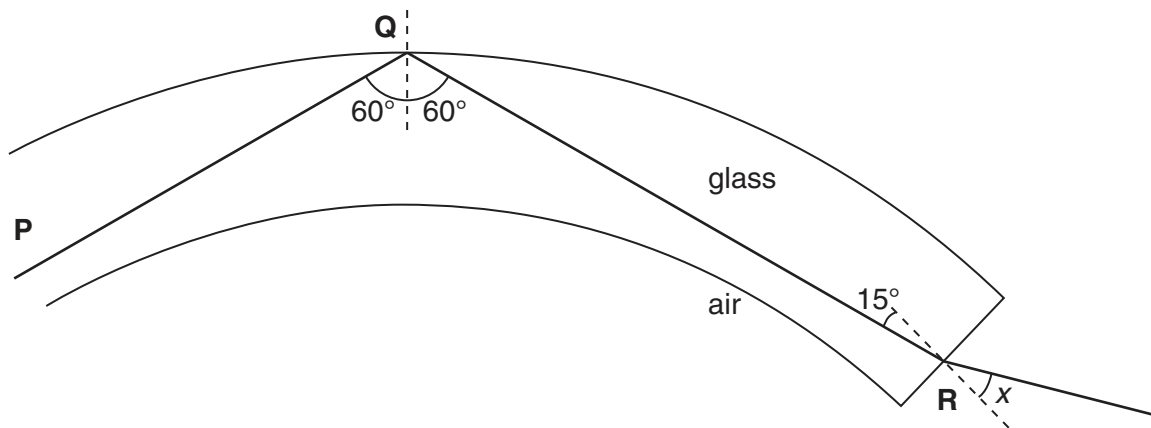

Fig. 2.1

(a) (i) Explain why the ray **PQ** does not leave the optical fibre at **Q**.

.....

(ii) Explain why the ray **QR** changes direction at **R**.

.....

[3]

(b) The refractive index of glass is 1.5. The ray **QR** makes an angle of 15° with the normal to the glass surface at **R**. Calculate the angle x , shown on Fig. 2.1.

angle $x = \dots\dots\dots$ [2]

(c) State one advantage of optical fibres rather than copper wires for carrying telephone communications.

.....

 [1]

3 Microwaves are waves in the electromagnetic spectrum.

(a) (i) State the name of waves in one other part of the electromagnetic spectrum that have wavelengths longer than microwaves.

.....[1]

(ii) A wave in the electromagnetic spectrum has a wavelength longer than microwaves. Explain why the frequency of this wave is lower than the frequency of microwaves.

.....
.....
.....
.....
.....[2]

(b) Microwaves are sometimes used to send telephone messages over long distances. They are sent from large dish aerials on top of high buildings or towers.

There are often several repeater or booster stations placed between the transmitter and the receiver, as illustrated in Fig. 3.1.

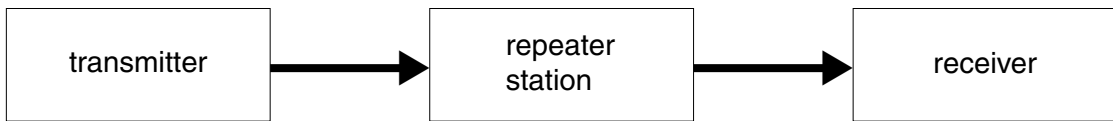

Fig. 3.1

State why

(i) the aerials are placed on top of high buildings or towers,

.....
.....

(ii) repeater or booster stations are necessary.

.....
.....

[2]

- 4 The owner of a house records the details of the electricity use of all the appliances during a day. The details are shown in Fig. 4.1.

appliance	power rating/kW	time switched on/ hours	energy used/kW h
TV and computer	1.0	2.0	
kettle	2.0	0.1	
lights	0.6	1.5	
water heater	3.0	0.4	
air conditioner	1.5	2.0	

Fig. 4.1

- (a) Complete Fig. 4.1 by calculating the energy used by each appliance. [2]

- (b) State which appliance has cost the most to use during the day.

.....[1]

- (c) The house has a meter to record the total electrical energy used. At the beginning of the day, the meter reading was 6350.5 kW h.
Calculate the meter reading at the end of the day.

meter reading = [1]

- (d) The wires supplying electric current to the water heater are thicker than those supplying current to the lights.
Explain why this is necessary.

.....

[2]

- 5 Fig. 5.1 shows the boiler of a coal-fired power station. Hot gases rise and thermal energy warms the water inside the metal pipes.

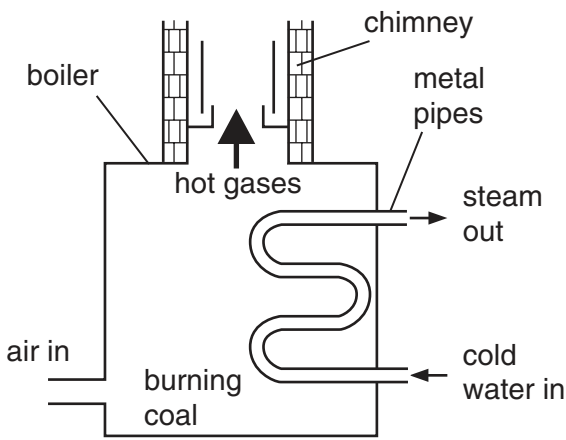

Fig. 5.1

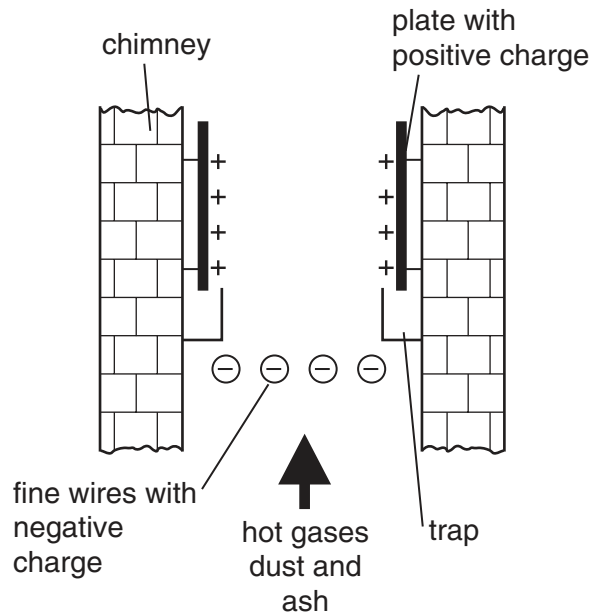

Fig. 5.2

- (a) (i) Explain why the hot gases rise.

.....

- (ii) Explain how energy passes through the metal pipes by conduction. Use your ideas about particles.

.....

[3]

- (b) Fig. 5.2 shows an electrostatic precipitator that stops dust and ash emerging from the chimney.

Explain how the precipitator works.

.....

[3]

- 6 Some details about nitrogen are given in Fig. 6.1.

	melting point °C	boiling point °C	specific heat capacity of liquid J/(g °C)	specific latent heat of vaporisation J/g
nitrogen	-210	-195	1.4	200

Fig. 6.1

- (a) At $-209\text{ }^{\circ}\text{C}$, will nitrogen be a solid, a liquid or a gas?

.....[1]

- (b) Define what is meant by *specific heat capacity*.

.....
.....[2]

- (c) Using data from the table, show that less energy is needed to warm liquid nitrogen from $-210\text{ }^{\circ}\text{C}$ to $-195\text{ }^{\circ}\text{C}$ than is needed to boil it.

.....
.....
.....[2]

- 7 Fig. 7.1 shows a syringe that contains gas at the same pressure as the air outside. The piston moves freely along the cylinder without any friction. No gas escapes.

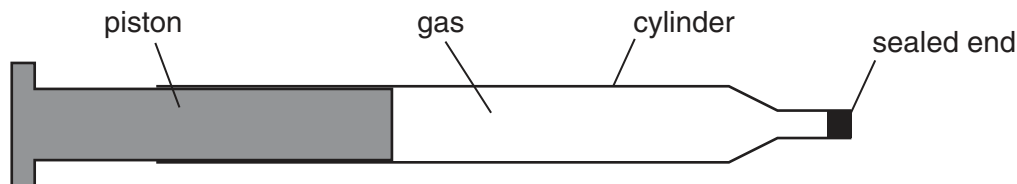

Fig. 7.1

As the syringe is heated from $20\text{ }^{\circ}\text{C}$ to $100\text{ }^{\circ}\text{C}$, the piston moves outwards. It stops moving when the temperature is steady. State how the value of each of the following quantities compares at $100\text{ }^{\circ}\text{C}$, after the piston stops, with its value at $20\text{ }^{\circ}\text{C}$.

For each quantity you should write *greater*, *the same* or *less*.

the average distance between the gas molecules	
the pressure of the gas after the piston stops	
the average speed of the gas molecules	
the frequency of the collisions between the gas molecules and the piston	

[4]

[Turn over

8 Details of two radioactive sources used by a school are shown in Fig. 8.1.

source	radioactive source	type of radiation emitted	half-life of source
A	Co-60	gamma ray	5 years
B	Sr-90	beta particle	28 years

Fig. 8.1

(a) On Fig. 8.2, the number of Co-60 atoms in source A and the number of Sr-90 atoms in source B at time $t = 0$ has been plotted as .

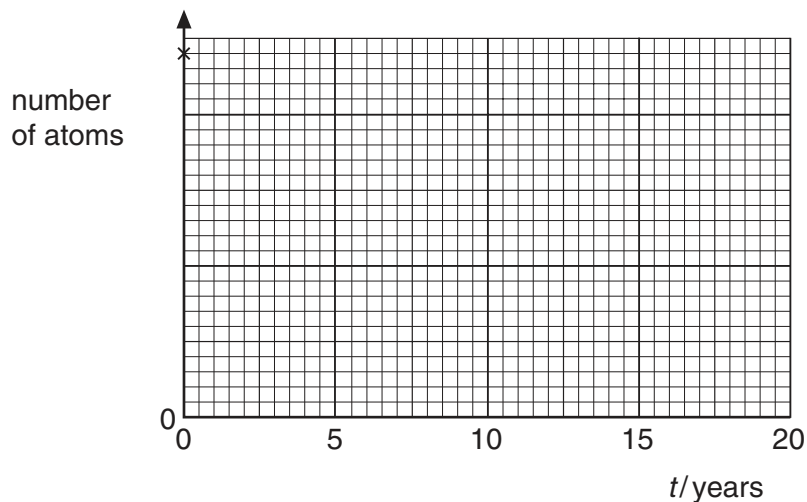

Fig. 8.2

- (i) Plot accurately the number of Co-60 atoms in source A at $t = 5, 10, 15$ and 20 years. Draw the best line through your points.
- (ii) Sketch how the number of Sr-90 atoms in source B changes from $t = 0$ to 20 years. [3]
- (b) A detector is placed near source A. It records 4000 counts in one minute from the source when $t = 0$.

A piece of lead, which absorbs 99% of gamma rays, is immediately placed between the source and the detector. Determine

- (i) the counts in one minute that the detector now records from the source,

counts in one minute =

- (ii) the time t when the detector would measure 10 counts in one minute from the source.

time =

[3]

Section B

Answer **two** questions from this section.

Use the separate answer sheets available from the Supervisor.

9 Energy can be changed from one form into another.

- (a) Solar energy is released from energy in the nuclei of atoms in the Sun. Some of this energy is converted into wind energy on the Earth.

Describe, in detail, the energy changes and processes that occur as the energy in the nuclei of atoms in the Sun is changed to wind energy on the Earth. [5]

- (b) A motor changes electrical energy into potential energy as it lifts a load.

A student measures the efficiency of this change, using the apparatus shown in Fig. 9.1.

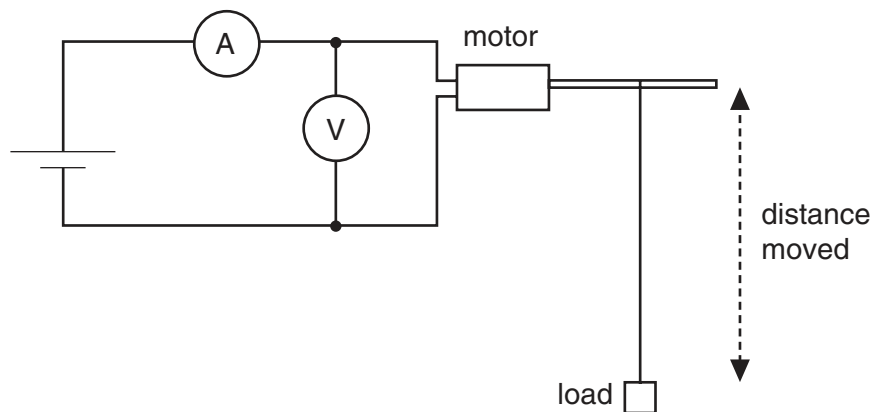

Fig. 9.1

The motor lifts the load at a steady speed. Fig. 9.2 shows the readings taken by the student.

load lifted/N	distance moved/m	time taken/s	p.d. across motor/V	current in motor/A
8.0	2.0	8.2	6.0	3.4

Fig. 9.2

- (i) Calculate
1. the work done in lifting the load,
 2. the electrical energy supplied to the motor,
 3. the efficiency of the motor.
- (ii) After the readings have been taken, the string breaks. State the major energy change that occurs as the load falls.

[10]

10 Fig. 10.1 shows a hand-operated hydraulic press.

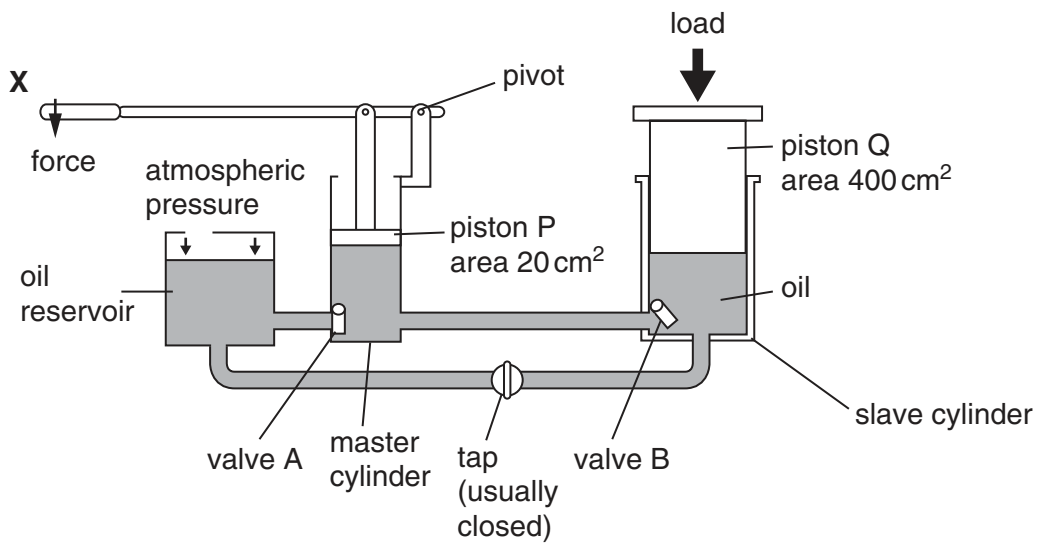

Fig. 10.1

A force is applied downwards at **X** as shown. Piston Q rises in the slave cylinder. The area of piston P is 20 cm^2 and the area of piston Q is 400 cm^2 .

- (a) Explain, in detail, how pushing **X** downwards causes piston Q to rise. State clearly what happens to valve A and to valve B. [5]
- (b) Piston P exerts a downward force of 300 N on the oil.
- Calculate the pressure, in N/cm^2 , exerted by piston P on the oil.
 - State the value of the pressure in the slave cylinder.
 - Calculate the force exerted by the oil on piston Q. [5]
- (c) Piston P moves down 5 cm.
- Calculate the volume of oil that moves out of the master cylinder.
 - Calculate the distance that piston Q rises. [2]
- (d) After **X** in Fig. 10.1 is pushed down, it is lifted up again. State what happens, as **X** is lifted, to valve A, to valve B and to the piston Q. [2]
- (e) State why oil, not air, is used in the hydraulic press. [1]

11 A student measures the speed of sound in a laboratory, as shown in Fig. 11.1.

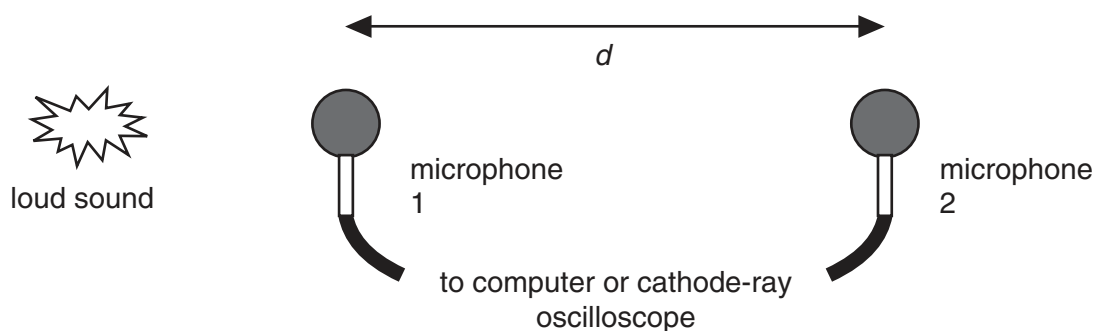

Fig. 11.1

The sound is received by two microphones placed a distance d apart. The time interval t between the sound arriving at the two microphones is recorded.

- (a) (i) Explain how sound travels through the air to the microphones.
 (ii) Explain why microphone 2 detects a quieter sound than microphone 1.

[5]

(b) Fig. 11.2 shows average values for t as d is varied.

d / m	1.00	2.00	3.00	4.00
t / s	0.0032	0.0060	0.0092	0.0121

Fig. 11.2

- (i) Draw a distance-time graph from the results given in Fig. 11.2.
 (ii) Using your graph, calculate the speed of sound in air.

[4]

(c) Fig. 11.3 shows the trace observed when the signals from the microphones are fed to the two inputs of a cathode-ray oscilloscope.

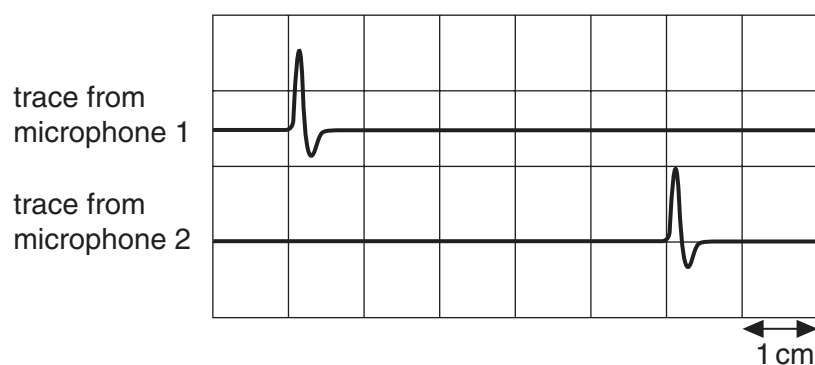

Fig. 11.3

Question 11 continues on the next page.

[Turn over

The time-base setting on the cathode-ray oscilloscope is 1.0 ms/cm.

- (i) Determine the time interval t from the trace in Fig. 11.3.
 - (ii) Using your answer to **(b)(ii)**, determine the distance d between the microphones. [2]
- (d) Give two reasons why it is difficult to measure the speed of sound inside a building using only a stopwatch and a metre rule. [2]
- (e) The experiment in **(b)** and **(c)** is repeated under water where the microphones can still detect the sound. State and explain how the experimental results differ. [2]